

T. J. Powers. Sheet 1. of 2 Sheets
Cartridge Loading.
N^o 90,871. Patented Jun. 1, 1869.

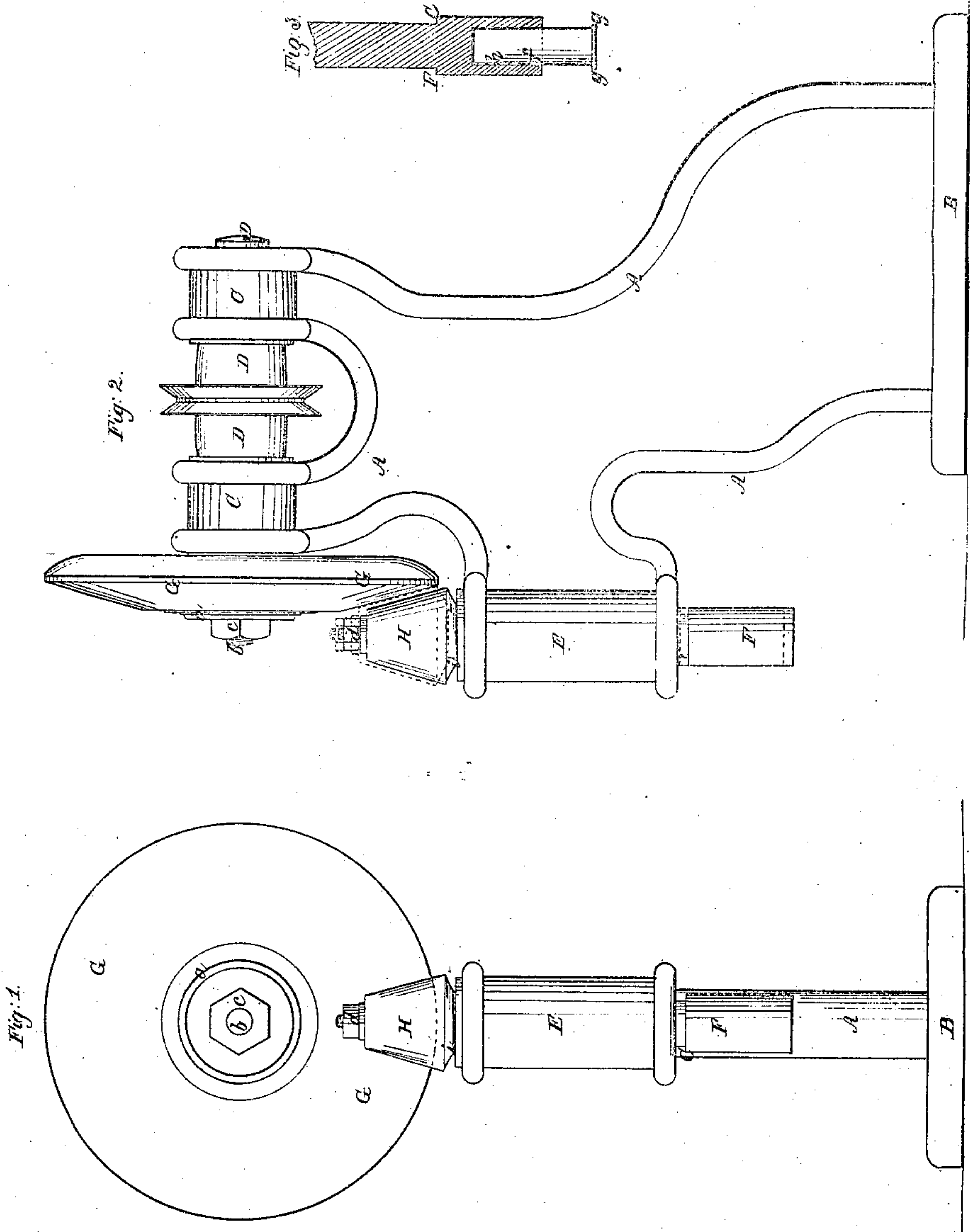

Witnesses
S. D. Crockett
Wm. J. Miller

Inventor,
T. J. Powers

I. J. Powers. *Sheet 2. of 2. Sheets.*
Cartridge Loading.
 No. 90,871. *Patented Jun. 1, 1869.*

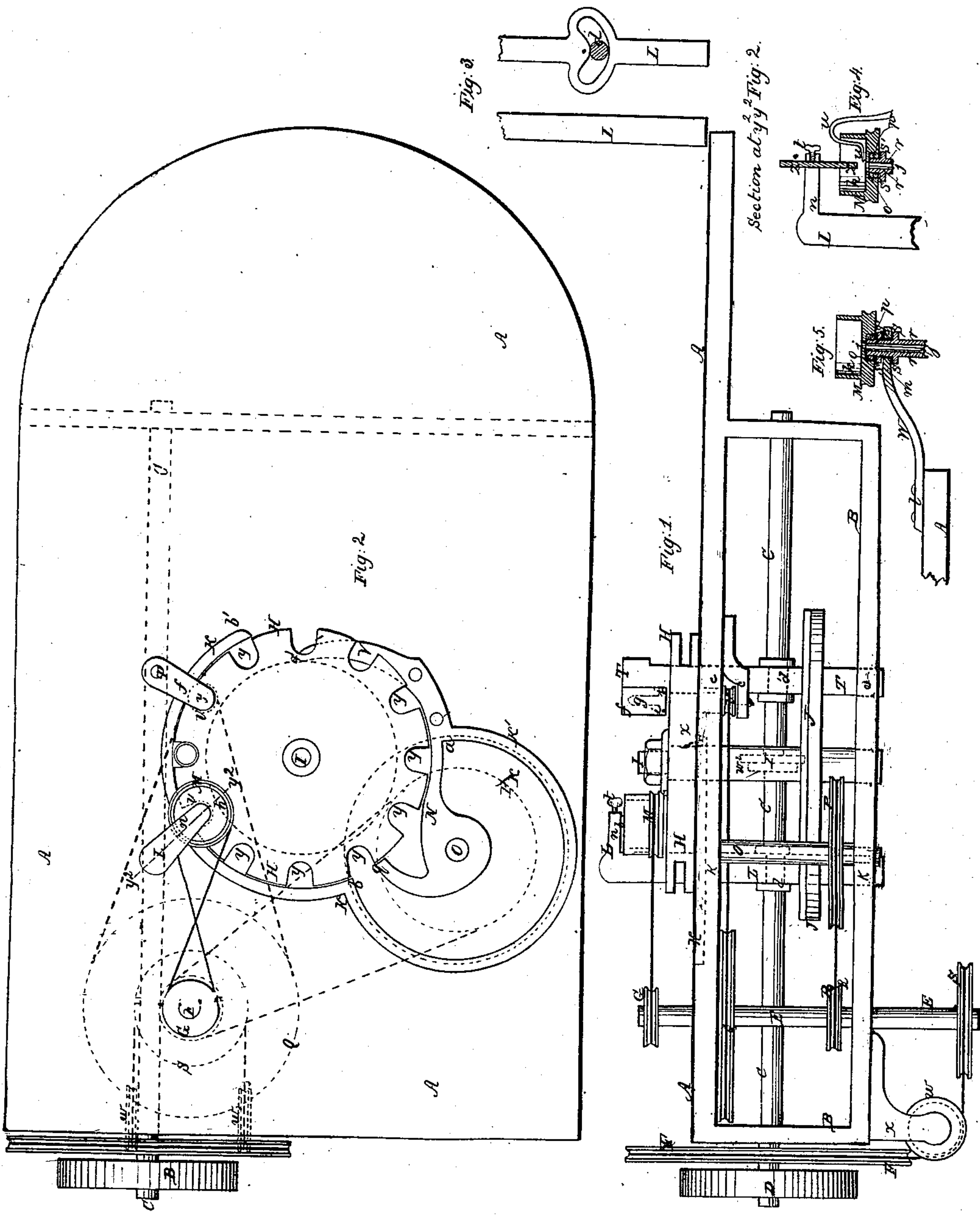

Witnesses
 S. D. Luzzardi
 J. A. Smith

Inventor,
 I. J. Powers

United States Patent Office.

TIMOTHY J. POWER, OF NEW YORK, N. Y., ASSIGNOR TO J. P. FITCH
AND J. R. VAN VECHTEN.

Letters Patent No. 90,871, dated June 1, 1869.

IMPROVEMENT IN PRIMING METALLIC CARTRIDGES.

The Schedule referred to in these Letters Patent and making part of the same.

To all whom it may concern :

Be it known that I, TIMOTHY J. POWER, of the city, county, and State of New York, have invented new and useful Apparatus for Priming Metallic Cartridges; and I hereby declare that the following is a full, clear, and exact description of the same, reference being had to the drawings which accompany and form a part of this specification.

Of these drawings—

Figure 1, plate 1, is a front elevation of one form of my apparatus, which may be conveniently operated by hand, though it may be driven by power, if desired;

Figure 2, same plate, is a side elevation of this apparatus; and

Figure 3, same plate, is a detail view, showing, in section, a part of the spindle which carries the cartridge-case, the latter being represented, in elevation, in its proper position in the spindle to be primed.

For the purpose of still more fully illustrating my invention, I have also shown in the drawings another form in which my apparatus may be constructed. This modification of it is specially designed to be operated by power, and

Figure 1, plate 2, represents a side view of it, and

Figure 2, same plate, a plan.

Figures 3, 4, and 5, same plate, are detail views.

Similar parts in each of the plates, respectively, are designated by similar letters.

This invention consists in priming cartridges by the employment of centrifugal force generated by spinning the shell on its own axis.

In the drawings—

A, plate 1, is the frame or body of the apparatus, which I prefer to make of a light casting.

B is a bench, table, or other suitable support, upon which the frame is bolted, or otherwise properly secured.

C C are heads, in which are formed suitable bearings, upon which the driving-shaft D revolves.

E is a lug, bored vertically, to receive the spindle or cartridge-carrier F, which is so fitted as to move easily up and down through the lug.

G is a bevelled friction-pulley, fast on the shaft D, and revolving with it.

H is another bevelled friction-pulley, fast on the spindle F, and so arranged and bevelled, relatively to the pulley G, that it is capable of being brought into contact with the bevelled face of the latter, when the spindle F is raised, and thereby rotated by the friction between its surface and that of the pulley G.

The lower end, *i*, of this pulley H, forms a shoulder,

which prevents the spindle F from slipping too far through the lug E.

The friction-faces of these pulleys G and H may be covered with leather, or constructed in any other manner which will provide for the requisite amount of friction between them.

The ends of the shaft D and spindle F, upon which these pulleys are respectively placed, terminate, respectively, in screw-threads *b* and *b'*, whereby, in connection with the nuts *c* and *d*, and (in the case of the shaft D) with the washer *a*, the pulleys are made properly fast on their shafts.

I is a pulley, also fast on the shaft B, over which may pass a driving-belt, to give motion to the apparatus when it is desired to operate it by power; or the shaft D may be driven by hand, by means of a crank fastened at its extremity, in any convenient manner.

The spindle or cartridge-carrier F, as shown, may be somewhat larger in diameter at its lower end than it is at the other parts of its length, in order more conveniently to receive the cartridge-cases *f*, and also in order to enable a shoulder, *i*, to be formed on it, to prevent the spindle from being raised, through the lug E, beyond a certain point.

This lower end of the spindle is designed to receive the cartridge-cases to be primed, and is bored of a diameter such that the cases, when inserted within it, with their flanged ends, *g*, downward, will fit into it snugly enough to be revolved with it when it is revolved, and of a depth such as to equal about half the length of the cases.

The operation of the apparatus is as follows:

The workman first introduces, in any convenient manner, into any desired number of the empty cartridge-cases, the requisite charge of detonate, and places the cases before himself, upon the bench or table upon which the apparatus is secured. He then takes them rapidly up in succession, and, with his thumb and finger, inserts them into the cavity, *h*, in the spindle, and, at the same time, presses the case and spindle upward with a slight force. This raises the spindle until the friction-pulley H comes in contact with the friction-pulley G, which latter is all the time rapidly revolving; and, as soon as this contact takes place, a similar rapid revolution is imparted to the spindle, and to the cartridge-case, and the liquid detonate is, by centrifugal force, driven into and properly deposited in the flange *g*. Only an instant is required to prime each case, and it is then withdrawn, by the workman, from the cavity *h*, and set aside till the detonate is dry.

In plate 1, the red lines show the position of the spindle when it is raised to be rotated by the pulley G.

In plate 2, A is the bed-piece of a machine, which will be seen to be somewhat larger than the one just described.

B is a frame, for supporting the various shafts to be hereafter mentioned.

O is the main driving-shaft, turning on suitable bearings in the frame B, and

D is the main driving-pulley.

E is another shaft, also turning on bearings in the frame and bed-piece A.

F is a pulley, fast on the shaft O; and from this pulley a band passes over the guide-pulleys *w w*, (which are secured on a shaft turning on bearings in ears *x x*, attached to the frame,) to the pulley S, on the shaft E, and thereby turns the shaft E, and also the pulleys G, Q, and R, which are fast upon it.

From the pulley G, a crossed band transmits motion to a pulley, M, which is best seen in fig. 4, and which is arranged as follows:

A bracket, W, is bolted, at *l*, to the bed A, and, at its forward end, a hole, *m*, is bored through it. Into this hole is fitted, so as to turn easily, a short shaft, *r*, provided with collars, *s* and *s'*, above and below the bracket, and so placed as to admit of the ready rotation of the shaft.

The pulley M is fast upon this shaft, and turns with it; and through the pulley and shaft a hole, *j*, is bored, the object of which will be explained presently.

From the pulley Q, a band transmits motion to a friction-pulley, U, on a short shaft, *v*, having its bearing in the arm *c*, attached to the under side of the bed-piece A.

From the pulley R, a band transmits motion to the pulley P, which is fast on and gives rotation to a shaft, O, turning in proper bearings in the frame B and bed-piece A.

H is a loading-wheel, for conveying the cartridge-cases which are to be primed to the receptacle in which the priming is contained. It is fast on and turns with the shaft I, which revolves on bearings in the frame B and bed-piece A.

J is a pulley, also fast on the shaft I; and upon the upper edge of its circumference it is provided with a worm-rack.

On the shaft O is an index-wheel or pinion, *w*², having, on a part of its circumference, a worm-screw, corresponding and gearing with the worm-rack on the pulley J.

This worm-rack and worm-screw are omitted from the drawing for the sake of convenience, but their construction will be readily understood by mechanics.

As the worm-screw is upon only a portion of the circumference of the pinion *w*², the pulley J will have an intermittent motion, being rotated only when that part of the pinion which has the screw upon it is in gear with the rack on the pulley; but the screw extends over a sufficient portion of the circumference of the pinion to give to the pulley J, at each partial rotation, a movement about equal to the distance from centre to centre, between two of the recesses, *y*, in the loading-wheel H; and, as this carrying-wheel is fast upon the shaft I, it has precisely the same motion as the pulley J, which drives it.

K is a feeding or hopper-wheel, fast on the shaft O, and driven by the pulley P, before referred to as being also fast on this same shaft O. This feed-wheel stands horizontally a little below the loading-wheel H, and has a constant revolution when the machine is in operation, and is designed to feed the empty cartridge-cases to the loading-wheel H.

K and N is a guide, which I prefer to cast in one piece. It is bolted or otherwise properly secured to the bed-piece A, and is so shaped and arranged, with

reference to the feed-wheel K, as to stand just outside of the latter, and to project above it far enough to constitute from *a* to *b*, fig. 2, a rim for said feed-wheel; and is also so shaped and arranged, with reference to the loading-wheel H, as to stand just outside thereof for a part of its circumference, and to project above it far enough to constitute, from *b* to *b'*, a rim for said loading-wheel.

The object of this guide is to properly direct, to and around the loading-wheel, the cartridge-cases which are introduced into the feeding-wheel preparatory to being charged; and from *a* to *b*, as well as from *a* to *g*, it performs this office; and from *a* to *v* it constitutes a finger, V, for discharging the cartridge-cases, after they are primed, out upon the top of the bed-piece A, which thus forms a table for the purpose.

Upon the upper side of the pulley M is placed a charging-hopper, *h*, which may be cast in one piece with the pulley, and which contains the detonate in a fluid state.

Over this hopper stands the arm *n* of a lifting-rod, L, which has a slight range of upward and downward travel, and which slides in proper bearing seats *j j*, in the frame B and bed-piece A. This lifting-rod is moved up and down by a crank-pin on the shaft C, shown in dotted lines at *d*, fig. 1, and also shown more fully in fig. 3.

This crank-pin works in a curved slot, in the lifting-rod L, as seen in fig. 3, and by its revolution, which causes it to travel from end to end of the slot, alternately raises and lowers the lifting-rod, in a manner which will be obvious.

Through the forward part of the arm *n* is thrust a wire, shown on an enlarged scale at *z z*, fig. 5, about one-eighth of an inch in diameter. This wire is capable of adjustment by the finger-screw *t*, and extends down into the liquid detonate in the hopper *h*, and is made of a size to pass easily through the hole *j*, in the shaft *r*.

The under side of the collar *s'* and the shaft *r* are counterbored, and into the counterbore is inserted a leather washer or packing, *o*, secured in place by a metal follower, *p*, which is screwed into the counterbore, and both the washer and the follower have a hole through them of the same size as that in the shaft *r*.

The washer *o* serves as a sort of stuffing-box for the wire *z*, but the detonate does not drop through the hole *j*, even when the wire is not in the latter.

A fixed stirrer, *u*, is properly secured at one end to the bed-piece A, while its other end enters the hopper, and bends forward nearly to the centre of the latter, and, during the rotation of the hopper, forces the detonate properly to the centre, so that a sufficient quantity is always beneath the wire *z*.

T is another lifting-rod, also having a slight upward and downward travel, and sliding in proper bearing-seats *e e*, in the frame B and bed-piece A. This lifting-rod is moved up and down by a crank-pin *d'*, in the shaft C, in a manner similar to the lifting-rod L, already described, and has at its upper end a shaft-arm, *f*, containing a seat into which fits easily a spindle, shown in dotted lines at *g*, fig. 1. The lower end of this spindle has cut in it an annular groove, *i*, into which the unflanged extremity of the cartridge-case is designed to fit.

y y are recesses in the loading-wheel to receive and hold the empty cartridge-cases while they are being conveyed by the loading-wheel to the charging-hopper *h*, to be primed, and, when loaded, to the finger V, to be thrown out upon the bed-piece or table A.

The operation of the machine is as follows:

The charging-hopper *a* is filled with liquor detonate; the parts are set in motion, and the workman feeds

by hand the empty cartridge-cases into the feeding-wheel K. This, by its revolution, carries them round till the foremost one enters one of the recesses *y*, in the loading-wheel, it being guided properly into the recess by the joint action of the parts K and N.

The worm-pinion *w*² is so combined with the worm-rack pulley J, that the screw on said pinion is in gear with said rack just when the empty cartridge-case enters its recess; and consequently, as soon as it enters, a partial rotation is imparted to the pulley J, and hence to the loading-wheel H, which latter, as it revolves in a direction opposite to the motion of the feeding-wheel, carries the cartridge-case forward a certain distance, when the pinion runs out of gear with the pulley and the loading-wheel stops. The pinion, however, continues to revolve, and soon comes again into gear with the pulley, and when it does so, the next case enters the next recess, and the loading-wheel is again turned the same distance.

This operation is repeated until the first cartridge-case has been carried underneath the charging-hopper *h*, by which time the pinion has again run out of gear and the loading-wheel has stopped.

The crank-pin *d*, on the driving-shaft C, is so arranged as to commence raising the lifting-rod L at the instant the pinion comes into gear with the pulley, and to cease to act upon it the instant the pinion runs out of gear with the pulley. Hence, whenever a cartridge-case comes underneath the charging-hopper *h*, the lifting-rod L, being no longer acted upon by the crank-pin, falls the entire length of its travel, and, in so doing, carries down with it the arm *n* and wire *z*, and thereby forces from the hopper *h* a small quantity sufficient for one charge, of the liquid detonate through the hole *j*, and drops it into the bottom of the cartridge-case.

As soon as this has been done, the pinion comes again into gear with the pulley, causing the loading-wheel to be again partially rotated, and carrying the primed cartridge away from the hopper *h* and towards the lifting-rod T.

When enough of these intermittent movements have been made to bring the primed case beneath the rod T, the latter drops, and thereby brings the annular groove *i*, in the spindle *g*, down upon the upper end of the case, over which it fits snugly, and also brings the lower end of the case down upon the friction-wheel U, which is all the time revolving with great rapidity.

The moment this takes place, the friction between the surface of the wheel U and the lower end of the cartridge-case, causes the latter, together with the spindle *g*, to be rotated with extreme velocity, the spindle, as before observed, being made to turn freely in its seat.

The centrifugal force thus developed throws the priming into its proper place in the flange of the cartridge-case; and as a single instant suffices for this, by the time the operation is complete, the lifting-rod T and the spindle *g* are raised by the crank-pin *d*, on the shaft C, clear of the cartridge-case, and the latter, at the next movement of the loading-wheel, is carried still further around toward the finger V, and, as soon as it reaches the latter, is discharged out of the wheel upon the top of the table or bed-piece A, or into any suitable receptacle. The same operation is repeated with each successive cartridge-case.

It is to be observed that the movements of the two lifting-rods L and T are so timed, that the former is charging one case at the same instant that the latter is forcing another case down upon the friction-wheel U.

I have described and recommended the use of fluid or semi-fluid detonate, and I consider that the safest and best form in which to use it in this process of priming; but I do not confine myself to that form or condition of detonate. It may be used in any state of fluidity or dryness, at the option of the manufacturer.

It will be obvious that many modifications may be made in either of the forms of apparatus above described, and that other and different apparatus may be constructed which will accomplish the same purpose. I therefore wish it to be distinctly understood, that I do not confine myself to any particular apparatus; nor do I claim as my invention the arrangement of the parts shown in plate 2 of the drawings.

I am aware that it is claimed that cartridges have been primed by hand, by revolving the shell in the horizontal plane of a circle, about a centre exterior to the shell. Whether this claim is true or not, I wish it to be understood that I do not claim that mode of priming cartridge-shells to be my invention. My invention consists in the priming of cartridges by centrifugal force, generated by revolving the shell on its own axis.

But having thus made known two forms in which my invention has been successfully applied in practice,

What I claim as new, and desire to secure by Letters Patent, is—

Charging cartridge-cases with detonate, by means of the centrifugal force generated by revolving the case on its own axis, substantially as described.

T J. POWER.

Witnesses:

S. D. COZZENS,
J. W. BUTLER.